

TRANSIL

FEATURES

- PEAK PULSE POWER= 600 W @ 1ms.
- BREAKDOWN VOLTAGE RANGE :
From 6V8 to 440 V.
- UNI AND BIDIRECTIONAL TYPES.
- LOW CLAMPING FACTOR.
- FAST RESPONSE TIME:
Tclamping : 1ps (0 V to VBR).
- UL RECOGNIZED.

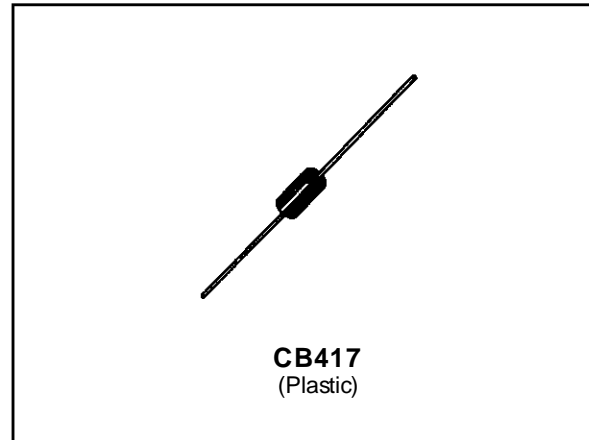

DESCRIPTION

Transil diodes provide high overvoltage protection by clamping action. Their instantaneous response to transients makes them particularly suited to protect voltage sensitive devices such as MOS Technology and low voltage supplied IC's.

MECHANICAL CHARACTERISTICS

- Body marked with : Logo, Date Code, Type Code, and Cathode Band (for unidirectional types only).
- Tinned copper leads.
- High temperature soldering.

ABSOLUTE RATINGS (limiting values)

Symbol	Parameter		Value	Unit
P_p	Peak pulse power dissipation See note 1 and derating curve Fig 1.	$T_{amb} = 25^{\circ}C$	600	W
P	Power dissipation on infinite heatsink See note 1 and derating curve Fig 1.	$T_{lead} = 75^{\circ}C$	5	W
I_{FSM}	Non repetitive surge peak forward current For Unidirectional types.	$T_{amb} = 25^{\circ}C$ $t = 10\text{ ms}$	100	A
T_{stg} T_j	Storage and junction temperature range		- 65 to + 175 175	$^{\circ}C$ $^{\circ}C$
T_L	Maximum lead temperature for soldering during 10 s.		230	$^{\circ}C$

P6KExx

THERMAL RESISTANCES

Symbol	Parameter	Value	Unit
R _{th (j-l)}	Junction-leads on infinite heatsink	20	°C/W
R _{th (j-a)}	Junction to ambient. on printed circuit. L _{lead} = 10 mm	85	°C/W

ELECTRICAL CHARACTERISTICS

Symbol	Parameter
V _{RM}	Stand-off voltage.
V _{BR}	Breakdown voltage.
V _{CL}	Clamping voltage.
I _{RM}	Leakage current @ V _{RM} .
I _{PP}	Surge current.
α _T	Voltage temperature coefficient.
V _F	Forward Voltage drop V _F < 3.5V @ I _F = 50 A.

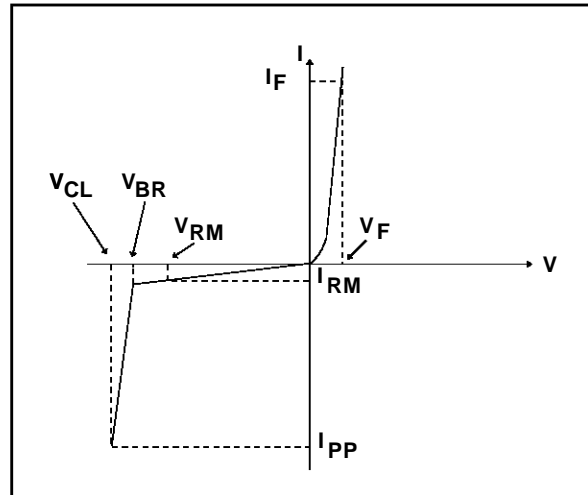

TYPES		I _{RM} @ V _{RM}		V _{BR} @ I _R				V _{CL} @ I _{PP}		V _{CL} @ I _{PP}		α _T	C
		max		min	nom	max		max	max	max	max	max	typ
		μA	V	note2				10/1000μs	8/20μs			note3	note4
Unidirectional	Bidirectional	μA	V	V	V	V	mA	V	A	V	A	10 ⁻⁴ /°C	(pF)
P P6KE6V8P	P P6KE6V8CP	1000	5.8	6.45	6.8	7.48	10	10.5	57	13.4	298	5.7	4000
P P6KE6V8A	P P6KE6V8CA	1000	5.8	6.45	6.8	7.14	10	10.5	57	13.4	298	5.7	4000
P6KE7V5P	P6KE7V5CP	500	6.4	7.13	7.5	8.25	10	11.3	53	14.5	276	6.1	3700
P6KE7V5A	P P6KE7V5CA	500	6.4	7.13	7.5	7.88	10	11.3	53	14.5	276	6.1	3700
P6KE8V2P	P P6KE8V2CP	200	7.02	7.79	8.2	9.02	10	12.1	50	15.5	258	6.5	3400
P P6KE8V2A	P6KE8V2CA	200	7.02	7.79	8.2	8.61	10	12.1	50	15.5	258	6.5	3400
P6KE9V1P	P6KE9V1CP	50	7.78	8.65	9.1	10	1	13.4	45	17.1	234	6.8	3100
P6KE9V1A	P6KE9V1CA	50	7.78	8.65	9.1	9.55	1	13.4	45	17.1	234	6.8	3100
P P6KE10P	P6KE10CP	10	8.55	9.5	10	11	1	14.5	41	18.6	215	7.3	2800
P6KE10A	P6KE10CA	10	8.55	9.5	10	10.5	1	14.5	41	18.6	215	7.3	2800
P6KE11P	P6KE11CP	5	9.4	10.5	11	12.1	1	15.6	38	20.3	197	7.5	2500
P6KE11A	P6KE11CA	5	9.4	10.5	11	11.6	1	15.6	38	20.3	197	7.5	2500
P P6KE12P	P P6KE12CP	5	10.2	11.4	12	13.2	1	16.7	36	21.7	184	7.8	2300
P6KE12A	P6KE12CA	5	10.2	11.4	12	12.6	1	16.7	36	21.7	184	7.8	2300
P6KE13P	P6KE13CP	5	11.1	12.4	13	14.3	1	18.2	33	23.6	169	8.1	2150
P P6KE13A	P P6KE13CA	5	11.1	12.4	13	13.7	1	18.2	33	23.6	169	8.1	2150
P P6KE15P	P P6KE15CP	5	12.8	14.3	15	16.5	1	21.2	28	27.2	147	8.4	1900
P6KE15A	P6KE15CA	5	12.8	14.3	15	15.8	1	21.2	28	27.2	147	8.4	1900
P6KE16P	P6KE16CP	5	13.6	15.2	16	17.6	1	22.5	27	28.9	138	8.6	1800
P6KE16A	P6KE16CA	5	13.6	15.2	16	16.8	1	22.5	27	28.9	138	8.6	1800
P P6KE18P	P P6KE18CP	5	15.3	17.1	18	19.8	1	25.2	24	32.5	123	8.8	1600
P P6KE18A	P P6KE18CA	5	15.3	17.1	18	18.9	1	25.2	24	32.5	123	8.8	1600
P6KE20P	P P6KE20CP	5	17.1	19	20	22	1	27.7	22	36.1	111	9.0	1500
P P6KE20A	P P6KE20CA	5	17.1	19	20	21	1	27.7	22	36.1	111	9.0	1500
P6KE22P	P P6KE22CP	5	18.8	20.9	22	24.2	1	30.6	20	39.3	102	9.2	1350

P = Preferred device

TYPES		IRM @ VRM		VBR @ R				VCL @ IPP		VCL @ IPP		αT	C
		max		min nom max				max		max		max	typ
				note2				10/1000μs		8/20μs		note3	note4
Unidirectional	Bidirectional	μA	V	V	V	V	mA	V	A	V	A	10 ⁻⁴ /°C	(pF)
	P6KE22A	5	18.8	20.9	22	23.1	1	30.6	20	39.3	102	9.2	1350
	P6KE24P	5	20.5	22.8	24	26.4	1	33.2	18	42.8	93	9.4	1250
P	P6KE24A	5	20.5	22.8	24	25.2	1	33.2	18	42.8	93	9.4	1250
P	P6KE27P	5	23.1	25.7	27	29.7	1	37.5	16	48.3	83	9.6	1150
	P6KE27A	5	23.1	25.7	27	28.4	1	37.5	16	48.3	83	9.6	1150
P	P6KE30P	5	25.6	28.5	30	33	1	41.5	14.5	53.5	75	9.7	1075
P	P6KE30A	5	25.6	28.5	30	31.5	1	41.5	14.5	53.5	75	9.7	1075
	P6KE33P	5	28.2	31.4	33	36.3	1	45.7	13.1	59.0	68	9.8	1000
P	P6KE33A	5	28.2	31.4	33	34.7	1	45.7	13.1	59.0	68	9.8	1000
P	P6KE36P	5	30.8	34.2	36	39.6	1	49.9	12	64.3	62	9.9	950
P	P6KE36A	5	30.8	34.2	36	37.8	1	49.9	12	64.3	62	9.9	950
P	P6KE39P	5	33.3	37.1	39	42.9	1	53.9	11.1	69.7	57	10.0	900
P	P6KE39A	5	33.3	37.1	39	41.0	1	53.9	11.1	69.7	57	10.0	900
	P6KE43P	5	36.8	40.9	43	47.3	1	59.3	10.1	76.8	52	10.1	850
	P6KE43A	5	36.8	40.9	43	45.2	1	59.3	10.1	76.8	52	10.1	850
	P6KE47P	5	40.2	44.7	47	51.7	1	64.8	9.3	84	48	10.1	800
	P6KE47A	5	40.2	44.7	47	49.4	1	64.8	9.3	84	48	10.1	800
	P6KE51P	5	43.6	48.5	51	56.1	1	70.1	8.6	91	44	10.2	750
	P6KE51A	5	43.6	48.5	51	53.6	1	70.1	8.6	91	44	10.2	750
	P6KE56P	5	47.8	53.2	56	61.6	1	77	7.8	100	40	10.3	700
	P6KE56A	5	47.8	53.2	56	58.8	1	77	7.8	100	40	10.3	700
	P6KE62P	5	53.0	58.9	62	68.2	1	85	7.1	111	36	10.4	650
	P6KE62A	5	53.0	58.9	62	65.1	1	85	7.1	111	36	10.4	650
	P6KE68P	5	58.1	64.6	68	74.8	1	92	6.5	121	33	10.4	625
	P6KE68A	5	58.1	64.6	68	71.4	1	92	6.5	121	33	10.4	625
	P6KE75P	5	64.1	71.3	75	82.5	1	103	5.8	134	30	10.5	575
	P6KE75A	5	64.1	71.3	75	78.8	1	103	5.8	134	30	10.5	575
	P6KE82P	5	70.1	77.9	82	90.2	1	113	5.3	146	27	10.5	550
	P6KE82A	5	70.1	77.9	82	86.1	1	113	5.3	146	27	10.5	550
	P6KE91P	5	77.8	86.5	91	100	1	125	4.8	162	25	10.6	525
	P6KE91A	5	77.8	86.5	91	95.5	1	125	4.8	162	25	10.6	525
	P6KE100P	5	85.5	95.0	100	110	1	137	4.4	178	22.5	10.6	500
	P6KE100A	5	85.5	95.0	100	105	1	137	4.4	178	22.5	10.6	500
	P6KE110P	5	94.0	105	110	121	1	152	3.9	195	20.5	10.7	470
	P6KE110A	5	94.0	105	110	116	1	152	3.9	195	20.5	10.7	470
	P6KE120P	5	102	114	120	132	1	165	3.6	212	19	10.7	450
	P6KE120A	5	102	114	120	126	1	165	3.6	212	19	10.7	450
	P6KE130P	5	111	124	130	143	1	179	3.4	230	17.5	10.7	420
	P6KE130A	5	111	124	130	137	1	179	3.4	230	17.5	10.7	420
	P6KE150P	5	128	143	150	165	1	207	2.9	265	15	10.8	400
P	P6KE150A	5	128	143	150	158	1	207	2.9	265	15	10.8	400
	P6KE160P	5	136	152	160	176	1	219	2.7	282	14	10.8	380
	P6KE160A	5	136	152	160	168	1	219	2.7	282	14	10.8	380
	P6KE170P	5	145	161	170	187	1	234	2.6	301	13	10.8	370
	P6KE170A	5	145	161	170	179	1	234	2.6	301	13	10.8	370
	P6KE180P	5	154	171	180	198	1	246	2.4	317	12.6	10.8	360
	P6KE180A	5	154	171	180	189	1	246	2.4	317	12.6	10.8	360
	P6KE200P	5	171	190	200	220	1	274	2.2	353	11.3	10.8	350
P	P6KE200A	5	171	190	200	210	1	274	2.2	353	11.3	10.8	350
	P6KE220P	5	188	209	220	242	1	328	2	388	10.3	10.8	330
	P6KE220A	5	188	209	220	231	1	328	2	388	10.3	10.8	330
	P6KE250P	5	213	237	250	275	1	344	2	442	9	11	310
	P6KE250A	5	213	237	250	263	1	344	2	442	9	11	310
	P6KE280P	5	239	266	280	308	1	384	2	494	8	11	300
	P6KE280A	5	239	266	280	294	1	384	2	494	8	11	300

P = Preferred device

P6KExx

TYPES		I _{RM} @ V _{RM}		V _{BR} @ R				V _{CL} @ I _{PP}		V _{CL} @ I _{PP}		αT	C
		max		min	nom	max		max		max		max	typ
				note2				10/1000μs		8/20μs		note3	note4
Unidirectional	Bidirectional	μA	V	V	V	V	mA	V	A	V	A	10 ⁻⁴ /°C	(pF)
P6KE300P	P6KE300CP	5	256	285	300	330	1	414	1.6	529	7.6	11	290
P6KE300A	P6KE300CA	5	256	285	300	315	1	414	1.6	529	7.6	11	290
P6KE320P	P6KE320CP	5	273	304	320	352	1	438	1.6	564	7.1	11	280
P6KE320A	P6KE320CA	5	273	304	320	336	1	438	1.6	564	7.1	11	280
P6KE350P	P6KE350CP	5	299	332	350	385	1	482	1.6	618	6.5	11	270
P P6KE350A	P6KE350CA	5	299	332	350	368	1	482	1.6	618	6.5	11	270
P P6KE400P	P P6KE400CP	5	342	380	400	440	1	548	1.3	706	5.7	11	360
P6KE400A	P6KE400CA	5	342	380	400	420	1	548	1.3	706	5.7	11	360
P P6KE440P	P P6KE440CP	5	376	418	440	484	1	603	1.3	776	5.2	11	350
P6KE440A	P6KE440CA	5	376	418	440	462	1	603	1.3	776	5.2	11	350

All parameters tested at 25 °C, except where indicated.

P = Preferred device

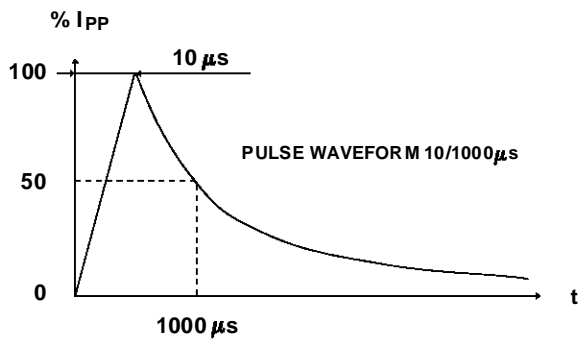
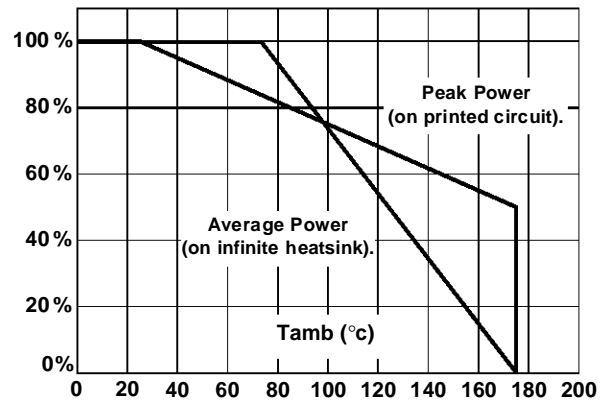

Figure 1: Power dissipation derating versus ambient temperature



Note 1 : For surges greater than the maximum values, the diode will present a short-circuit Anode - Cathode.

Note 2 : Pulse test: T_P < 50 ms.

Note 3 : $\Delta V_{BR} = \alpha T \cdot (T_a - 25) \cdot V_{BR(25^\circ C)}$.

Note 4 : V_R = 0 V, F = 1 MHz. For bidirectional types, capacitance value is divided by 2.

Figure 2 : Peak pulse power versus exponential pulse duration.

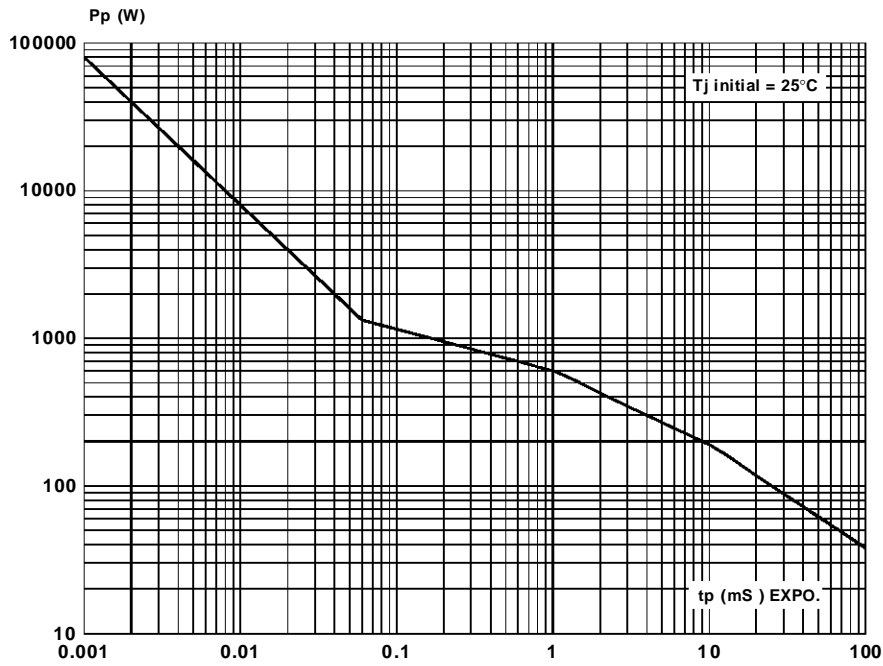
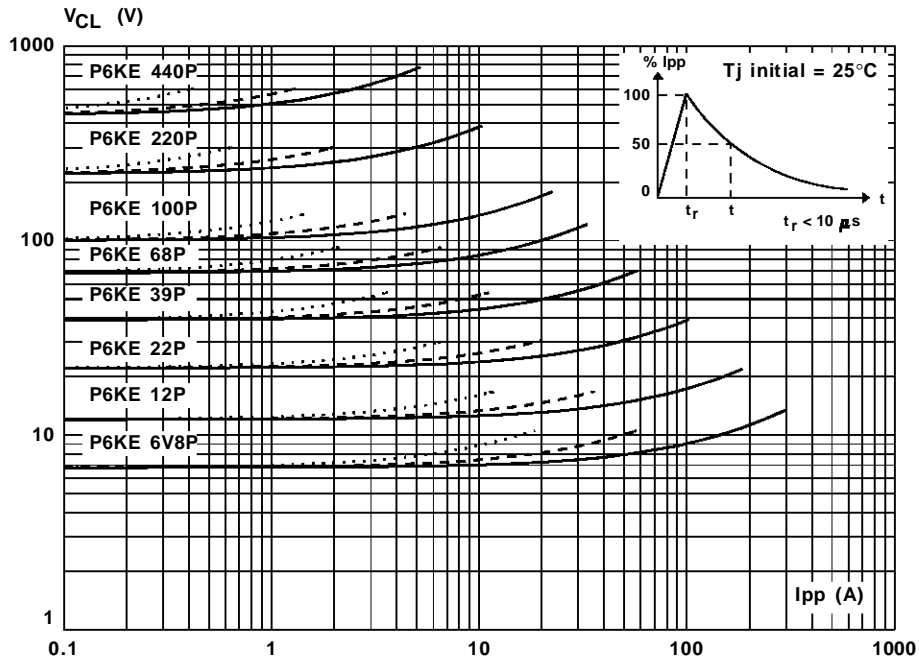

Figure 3 : Clamping voltage versus peak pulse current.

exponential waveform $t = 20 \mu\text{s}$ _____
 $t = 1 \text{ ms}$ - - - - -
 $t = 10 \text{ ms}$
 Tj initial = 25°C



Note : The curves of the figure 3 are specified for a junction temperature of 25 °C before surge.
 The given results may be extrapolated for other junction temperatures by using the following formula :
 $\Delta V (BR) = \alpha T (V(BR)) * [T_a - 25] * V (BR)$.
 For intermediate voltages, extrapolate the given results.

Figure 4a : Capacitance versus reverse applied voltage for unidirectional types (typical values).

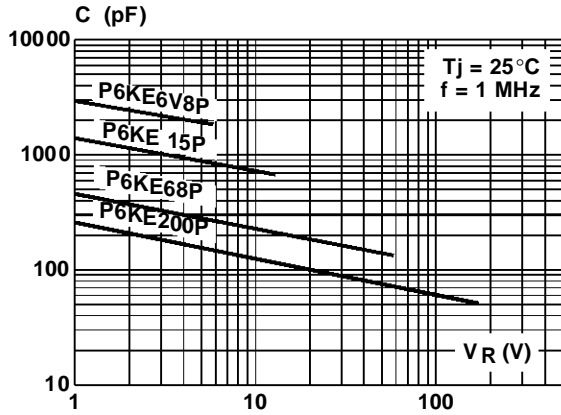

Figure 4b : Capacitance versus reverse applied voltage for bidirectional types (typical values)

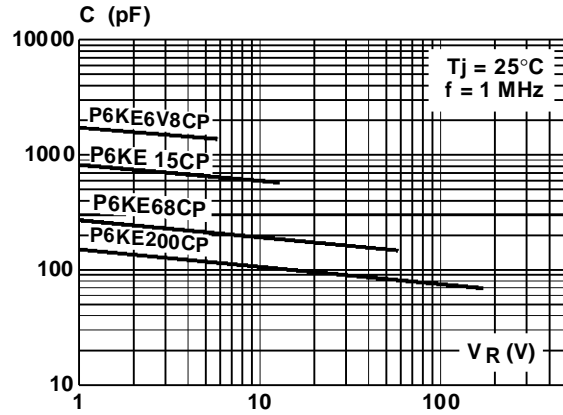

Figure 5 : Peak forward voltage drop versus peak forward current (typical values for unidirectional types).

Note : For units with $V_{BR} > 200\text{ V}$
 V_F is twice than shown.

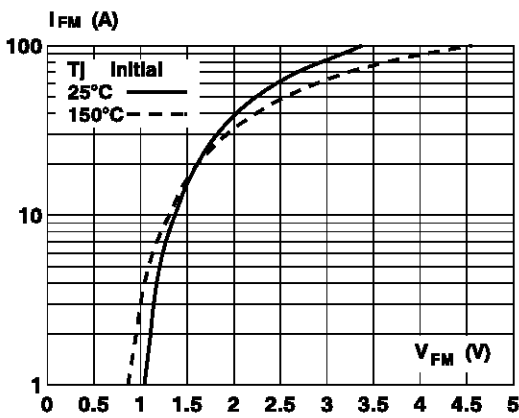
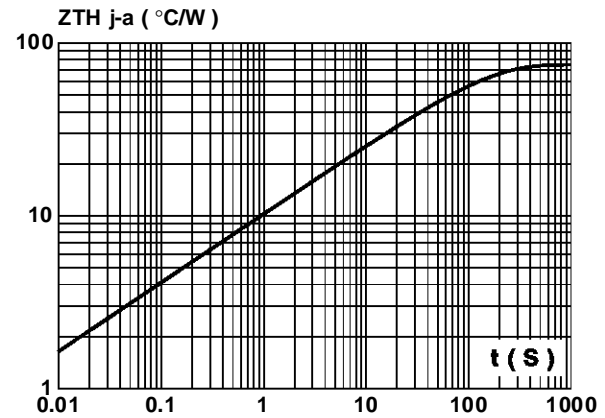
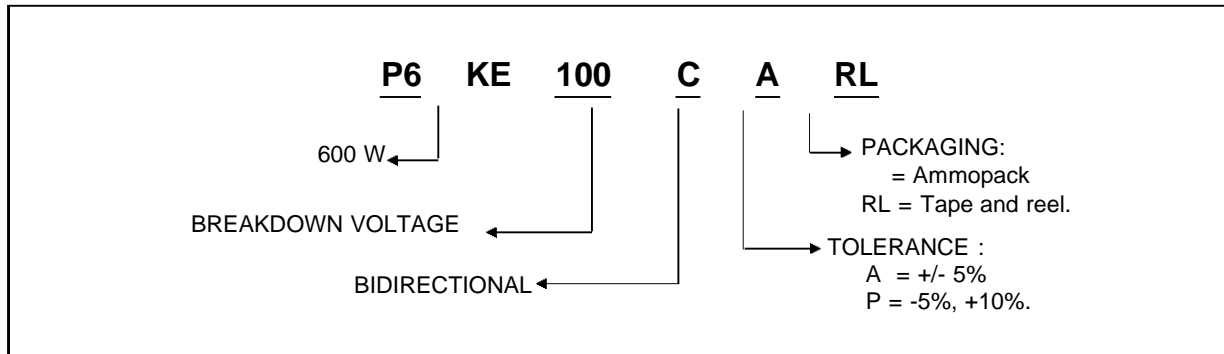

Figure 6 : Transient thermal impedance junction-ambient versus pulse duration. For a mounting on PC Board with $L_{lead} = 10\text{mm}$.



ORDER CODE



MARKING : Logo, Date Code, Type Code, Cathode Band (for unidirectional types only).

PACKAGE MECHANICAL DATA

CB417 (Plastic).

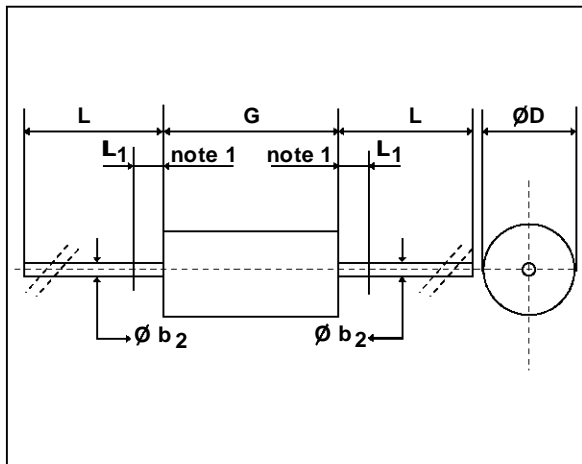

Ref	Millimeters		Inches	
	min	max	min	max
Ø b ₂	-	1.092	-	0.043
Ø D	-	3.683	-	0.145
G	-	8.89	-	0.350
L	25.4	-	1.000	-
L ₁	-	1.25	-	0.049

note1:The diameter Ø b₂ is not controlled over zone L₁.

Weight = 0.65 g.

Packaging : standard packaging is in tape and reel.

Information furnished is believed to be accurate and reliable. However, SGS-THOMSON Microelectronics assumes no responsibility for the consequences of use of such information nor for any infringement of patents or other rights of third parties which may result from its use. No license is granted by implication or otherwise under any patent or patent rights of SGS-THOMSON Microelectronics. Specifications mentioned in this publication are subject to change without notice. This publication supersedes and replaces all information previously supplied. SGS-THOMSON Microelectronics products are not authorized for use as critical components in life support devices or systems without express written approval of SGS-THOMSON Microelectronics.

© 1994 SGS-THOMSON Microelectronics - All Rights Reserved

Purchase of I²C Components by SGS-THOMSON Microelectronics, conveys a licence under the Philips I²C Patent. Rights to use these components in an I²C system, is granted provided that the system conforms to the I²C Standard Specification as defined by Philips.

SGS-THOMSON Microelectronics GROUP OF COMPANIES
Australia - Brazil - France - Germany - Hong Kong - Italy - Japan - Korea - Malaysia - Malta - Morocco - The Netherlands -
Singapore - Spain - Sweden - Switzerland - Taiwan - Thailand - United Kingdom - U.S.A